

●特点(Features):

1. 芯片材料(Chip material): InGaN/SiC
2. 发光颜色(Emitted color): Super White
3. 透镜外表(Lens Appearance): Water Clear
4. 低耗能(Low power consumption)
5. 高效率(High efficiency.)
6. 低电流(Low current requirement).

●应用(Applications):

1. 电视机(TV set)
2. 监视器(Monitor)
3. 电话(Telephone)
4. 计算机(Computer)
5. 电路板(Circuit board)

● Package dimensions:

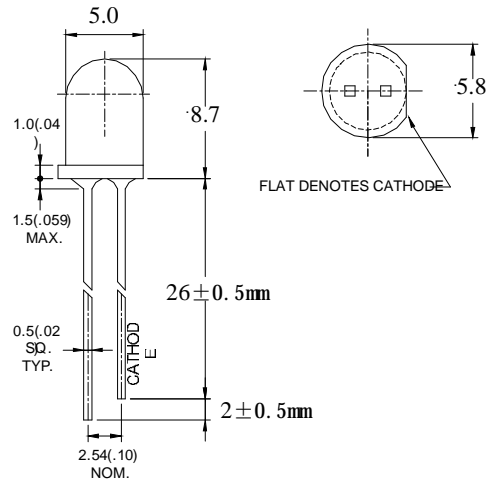

Notes:

1. All dimensions are in millimeters (inches).
2. Tolerance is $\pm 0.25\text{mm}$ (0.01") unless otherwise specified.
3. Lead spacing is measured where the leads emerge from the package.
4. Specifications are subject to change without notice.

I 最大額定(Absolute Maximum Ratings)···(Ta=25°C)

Parameter	Symbol	Rating	Unit
功率消耗(Power Dissipation)	Pd	70	mW
顺向电流(Forward Current)	I _F	20	mA
峰值电流(Peak Forward Current ^{*1})	I _{FP}	100	mA
逆向电压(Reverse Voltage)	V _R	5	V
操作温度(Operating Temperature)	Topr	-40°C~80°C	
保存温度(Storage Temperature)	Tstg	-40°C~85°C	
焊接温度(Soldering Temperature)	Tsol	260°C (for 5 seconds)	

*1Condition for I_{FP} is pulse of 1/10 duty and 0.1msec width.

● Electrical and optical characteristics(Ta=25°C)

Parameter	Symbol	Condition	Min.	Typ.	Max.	Unit
Forward Voltage	V_F	$I_F=20\text{mA}$	2.8		3.5	V
Luminous Intensity	I_v	$I_F=20\text{mA}$	15000		22000	mcd
Reverse Current	I_R	$V_R=5\text{V}$			5	μA
Chromatically Coordinates(note 4)	X	$I_F=20\text{mA}$	-	0.27	-	--
	Y	$I_F=20\text{mA}$	-	0.26	-	--
Spectral Line Half-width	$\Delta\lambda$	$I_F=20\text{mA}$	-		5	nm
Viewing Angle	$2\theta_{1/2}$	$I_F=20\text{mA}$	-	15	-	deg

● Typical Electro-Optical Characteristics Curves

Fig.1 Relative intensity vs. Wavelength

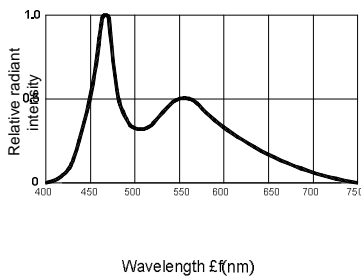

Fig.2 Forward current operating curve vs. Ambient temperature

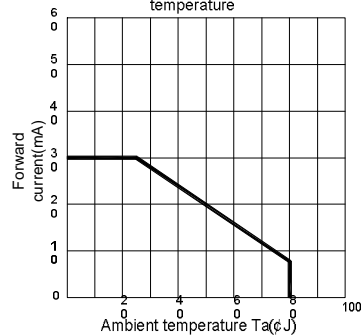

Fig.3 Forward current vs. Forward voltage

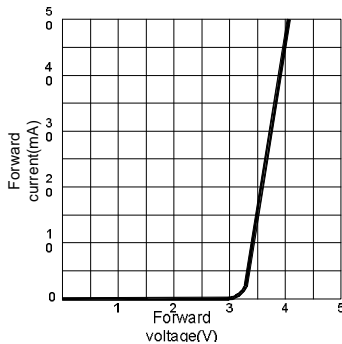

Fig.4 Relative luminous intensity vs. Ambient temperature

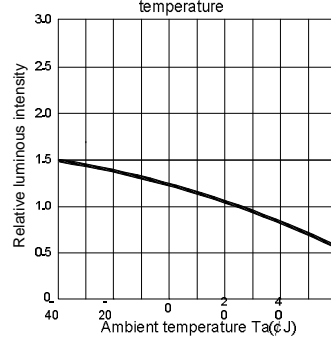

Fig.5 Relative luminous intensity vs. Forward current

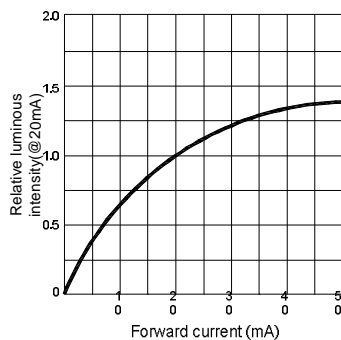
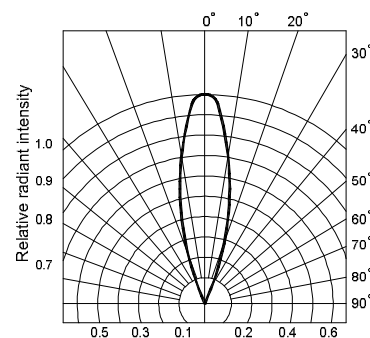

Fig.6 Radiation diagram



● Reliability Test

Classification	Test Item	Reference Standard	Test Conditions	Result
Endurance Test	Operation Life	MIL-STD-750:1026 MIL-STD-883:1005 JIS-C-7021 :B-1	Connect with a power If=20mA Ta=Under room temperature Test time=1,000hrs	0/20
	High Temperature High Humidity Storage	MIL-STD-202:103B JIS-C-7021 :B-11	Ta=+65°C±5°C RH=90%-95% Test time=240hrs	0/20
	High Temperature Storage	MIL-STD-883:1008 JIS-C-7021 :B-10	High Ta=+85°C±5°C Test time=1,000hrs 0/20	0/20
	Low Temperature Storage	JIS-C-7021 :B-12	Low Ta=-35°C±5°C Test time=1,000hrs	0/20
Environmental Test	Temperature Cycling	MIL-STD-202:107D MIL-STD-750:1051 MIL-STD-883:1010 JIS-C-7021 :A-4	-35°C ~ +25°C ~ +85°C ~ +25°C 60min 20min 60min 20min Test Time=5cycle	0/20
	Thermal Shock	MIL-STD-202:107D MIL-STD-750:1051 MIL-STD-883:1011	35°C±5°C ~+85°C±5°C 20min 20min Test Time=10cycle	0/20
	Solder Resistance	MIL-STD-202:201A MIL-STD-750:2031 JIS-C-7021 :A-1	Preheating : 140 °C -160 °C ,within 2 minutes. Operation heating : 235 °C (Max.), within 10seconds. (Max.)	0/20

● TJudgment criteria of failure for the reliability

Measuring items	Symbol	Measuring conditions	Judgement criteria for failure
Forward voltage	V _F (V)	I _F =20mA	Over U _x 1.2
Reverse current	I _R (uA)	V _R =5V	Over U _x 2
Luminous intensity	I _v (mcd)	I _F =20mA	Below SX0.5

Notes:

1. U means the upper limit of specified characteristics. S means initial value.
2. Measurment shall be taken between 2 hours and after the test pieces have been returned to normal ambient conditions after completion of each test.

● Soldering :

1. Manual Of Soldering

The temperature of the iron tip should not be higher than 300°C (572°F) and Soldering within 3 seconds per solder-land is to be observed.

2. Reflow Soldering

Preheating : 140°C~160°C ±5°C ,within 2 minutes.

Operation heating : 235°C (Max.) within 10 seconds.(Max)

Gradual Cooling (Avoid quenching).

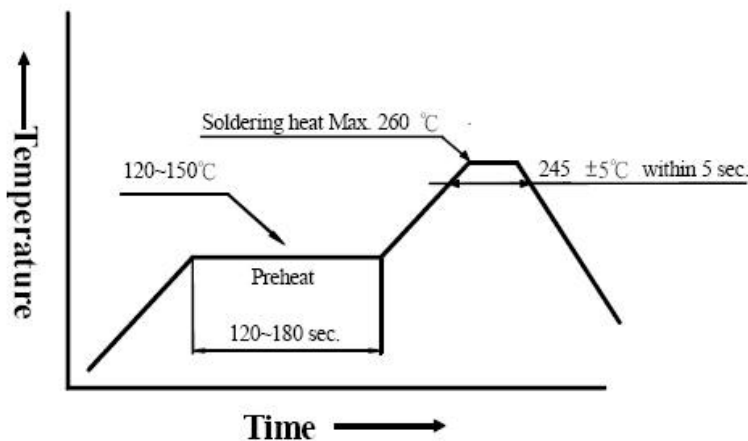

3. DIP soldering (Wave Soldering) :

Preheating : 120°C~150°C ,within 120~180 sec.

Operation heating : 245°C ±5°C within 5 sec. 260°C (Max)

Gradual Cooling (Avoid quenching).

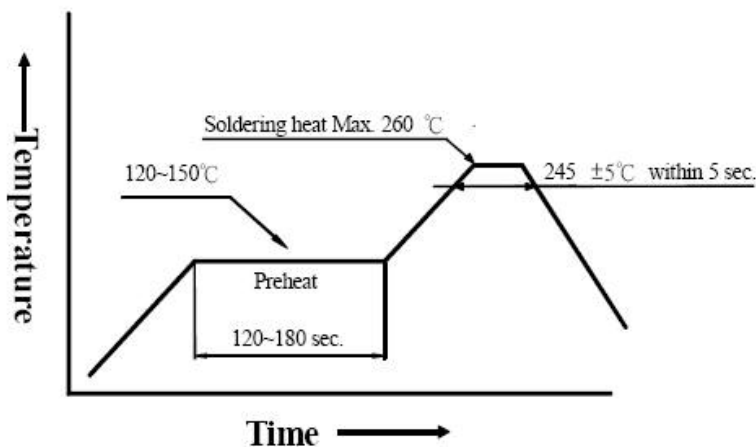

● Handling :

Care must be taken not to cause to the epoxy resin portion of TOPTEN LEDs while it is exposed to high temperature.

Care must be taken not rub the epoxy resin portion of TOPTEN LEDs with hard or sharp article such

as the sand blast and the metal hook.

● **Notes for designing:**

Care must be taken to provide the current limiting resistor in the circuit so as to drive the TOPTEN LEDs within the rated figures. Also, caution should be taken not to overload TOPTEN LEDs with instantaneous voltage at the turning ON and OFF of the circuit.

When using the pulse drive care must be taken to keep the average current within the rated figures. Also, the circuit should be designed so as be subjected to reverse voltage when turning off the TOPTEN LEDs.

● **Storage:**

In order to avoid the absorption of moisture, it is recommended to solder TOPTEN LEDs as soon as possible after unpacking the sealed envelope.

If the envelope is still packed, to store it in the environment as following:

- (1) Temperature : 5°C -30°C (41°F) Humidity : RH 60% Max.
- (2) After this bag is opened, devices that will be applied to infrared reflow, vapor-phase reflow, or equivalent soldering process must be:
 - a. Completed within 24 hours.
 - b. Stored at less than 30% RH.
- (3) Devices require baking before mounting, if:
 - (2) a or (2) b is not met.
- (4) If baking is required, devices must be baked under below conditions:
 - 12 hours at 60°C ±3°C.

● **Package and Label of Products:**

- (1) Package: Products are packed in one bag of 500 pcs (one taping reel) and a label is attached on each bag.
- (2) Label:

